

# 提夫自控技术（上海）有限公司



KI1000

电气参数		
标称阻值	5 k	KOhm
阻值精度	±20	%
独立线性度	±1	% of meas. range
电气行程	100	mm
可重复性	0.05	mm
分压器温度系数	50	ppm/°C
推荐滑动片电流	max. 1	µA
故障失灵滑动片最大电流	10	mA
功率P	max. 0.5	W/40°C
最小寿命(电气)	10 Mio.	cycles

机械参数		
机械行程	100	mm
推杆调节力	max. 3	N
最小寿命(机械)	max. 10	N
工作温度	-25 ... +75	°C
储存温度	-25 ... +105	°C
防护等级	IP65	

标准		
绝缘电阻(500 VDC, 1bar, 2s)	10	GOhm
绝缘强度(VAC, 50Hz, 1min, 1bar)	700	V
振动(Amax = 0.75mm, f = 30 ... 2000 Hz)	10	g
冲击(half sine pulse, 7 ms)	50	g

## 应用

- 汽车加速踏板

## 产品特点

- 小体积
- 适应性设计
- 5 Mio. 转
- 极好的线性度高达 ±0.25%
- 非常好的分辨率, 好于0,05mm

## 可选

- 线性度 ±0.25 %
- 标称阻值 1KOhm 到 20KOhm
- 推杆槽
- 更长推杆
- 线缆连接
- 更长电缆
- 串联加固
- 不带螺纹
- 带螺纹M6x0.75 or M10x0.75
- 带或不带回拉弹簧



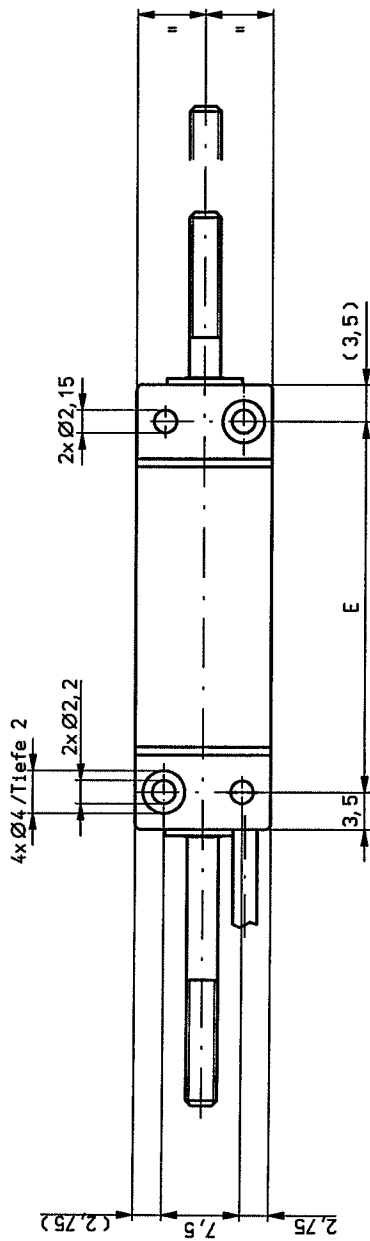
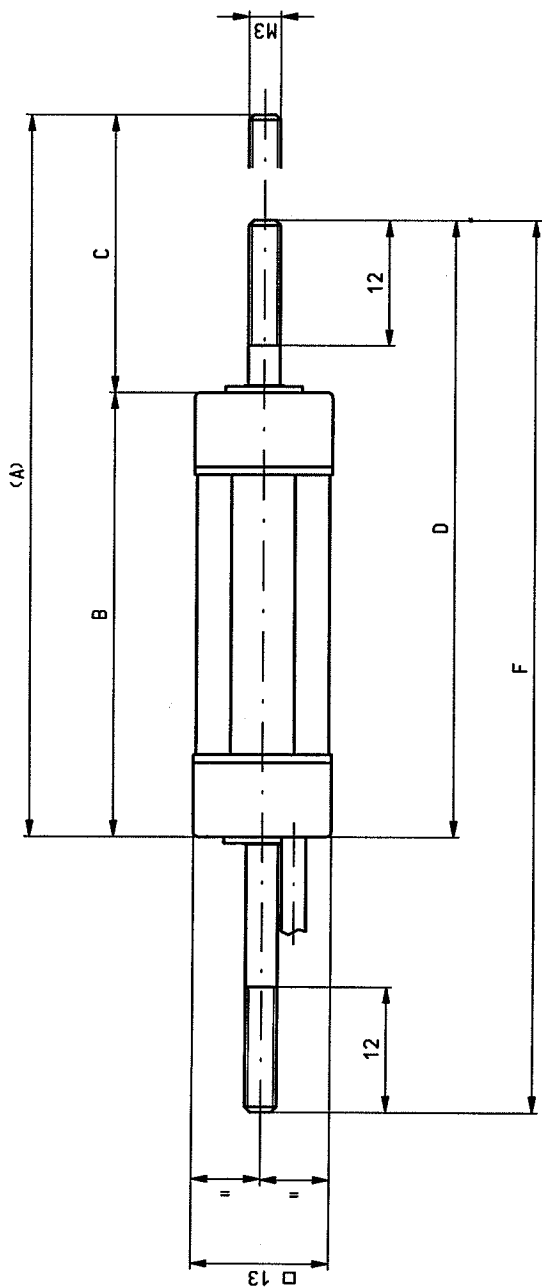

Typ	Ar.-Nr.	Elektr. Hub	Linearität	A	B	C	D	E	F
KL 100-1K0/M-SD	70437	10	±1%	68.5	42	26.5	58.5	35	85
KL 100-1K0/M-SD	70822	10	±0.5%	68.5	42	26.5	58.5	35	85
KL 250-5K0/M-SD	70440	25	±1%	98.5	57	41.5	73.5	50	115
KL 250-5K0/M-SD	70825	25	±0.25%	98.5	57	41.5	73.5	50	115
KL 500-5K0/M-SD	70443	50	±1%	148.5	82	66.5	98.5	75	165
KL 500-5K0/M-SD	70828	50	±0.25%	148.5	82	66.5	98.5	75	165

Pos	Menge	Elt	Abmessung	Werkstoff	Gewicht	Bemerkung	Ar.-Nr.
2							
6				©	Allg. Tol.	SN 258440-m	I. Kl.
5							
4							
3							
2							
1							
Nr.	Anderung	Ind.	Datum	Name	Ursp.		
					F:12910_A		
				CONTELEC AG			
				CH-2503 BIEL			
				MB3	12910	A	99

## CONTELEC

# 提夫自控技术（上海）有限公司

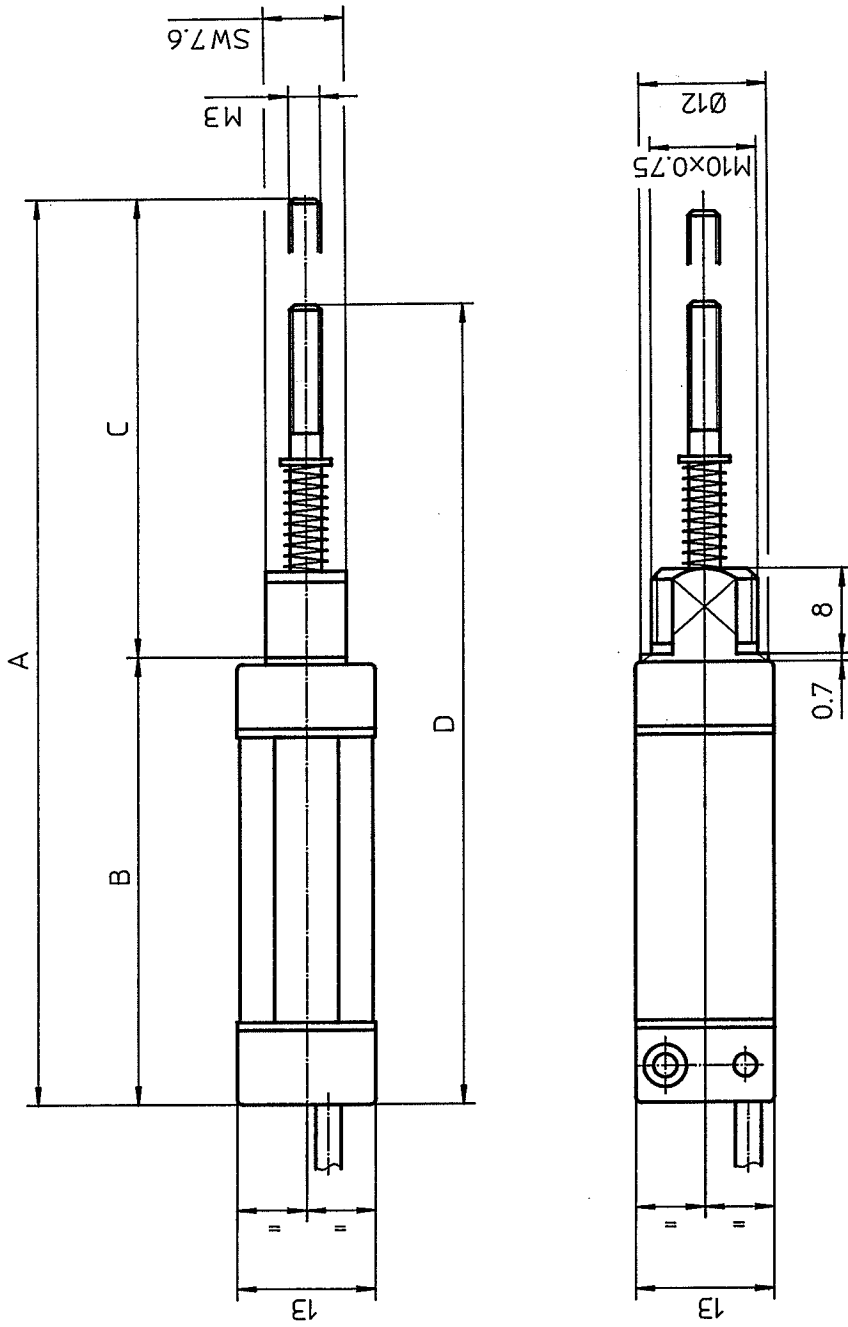

Typ	Art.-Nr.	Elektr. Hublänge gesamt	Linearität	A	B	C	D
KL 100-1K0/M-SEFZM	82656	10	±1%	85.2	41.7	43.5	75.2
KL 100-1K0/M-SEFZM	82657	10	±0.5%	85.2	41.7	43.5	75.2
KL 250-5K0/M-SEFZM	82658	25	±1%	125.2	56.7	68.5	100.2
KL 250-5K0/M-SEFZM	82659	25	±0.25%	125.2	56.7	68.5	100.2
KL 500-5K0/M-SEFZM	<del>82660</del> 82661	50	±1%	185.2	81.7	103.5	135.2
KL 500-5K0/M-SEFZM	82661	50	±0.25%	185.2	81.7	103.5	135.2

Menge	Einheit	Artikel-Nr.	Ind.	Bezeichnung 1	Bemerkungen
1	A	04.07.97 gm	4.		
2	A	06.12.04 /msf	5.		
3			6.		
Gezeichnet		18.11.96	OG	Projektion Vorg.Zeichng: Folge-Zeichng: T. Kl. 07.03	
Geprüft		4.07.97		Massstab 2:1 Allg. tel. SN 258440 mittel	
Normgepr.				Bezeichn. 1 MB KL-SEFZM (Kabel)	
Freigabe				Bezeichn. 2 KL 100-1000	
CONIELEC			CONIELEC AG		A 99
			CH-2503-BIEL		12920
			MB3		

Für diese Zeichnung behalten wir uns alle Rechte vor

# 提夫自控技术（上海）有限公司

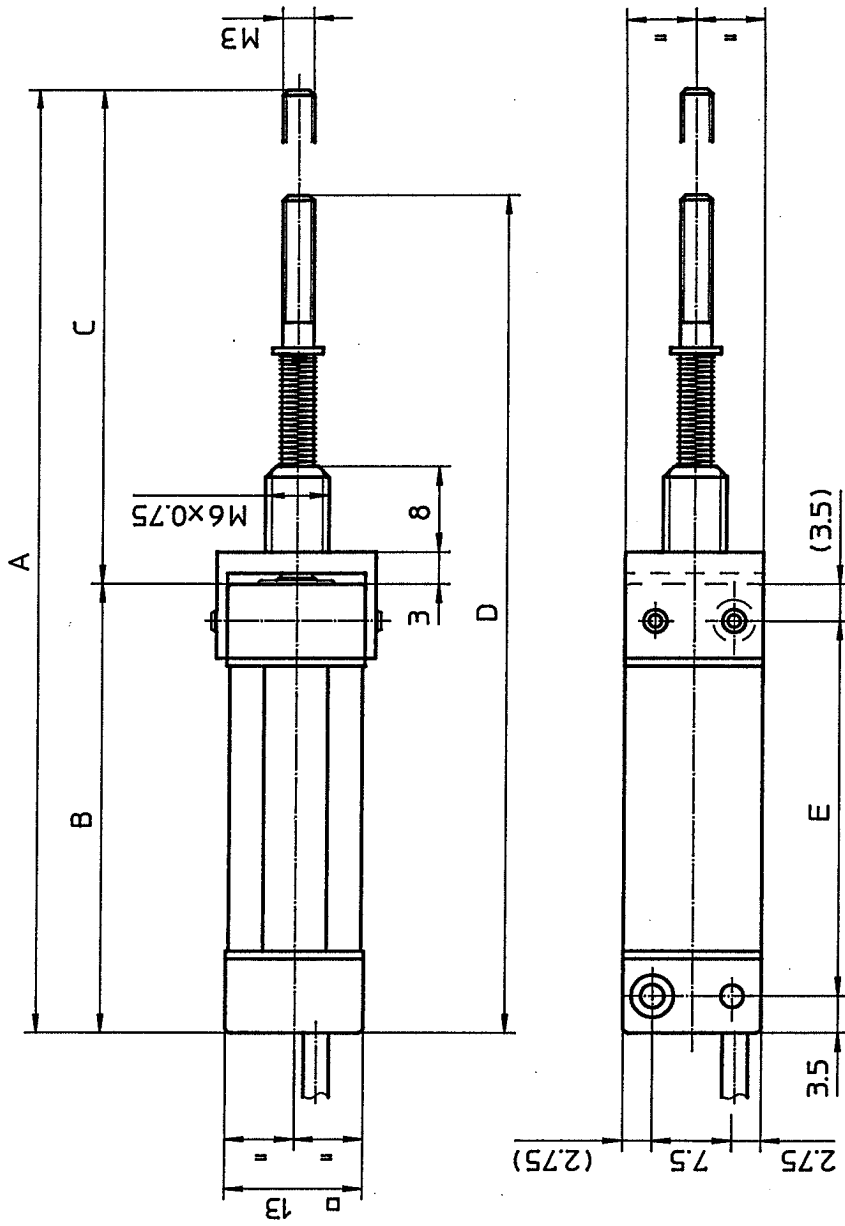

Typ	Art.-Nr.	Elektr. Hübänge gesamt	Linearisiert	Linearität	A	B	C	D	E
KL 100-1K0/M-SEFZN	82236	10	-	±1%	88.5	42	46.5	78.5	35
KL 100-1K0/M-SEFZN	82402	10	9	±0.5%	88.5	42	46.5	78.5	35
KL 250-5K0/M-SEFZN	82238	25	-	±1%	128.5	57	71.5	103.5	50
KL 250-5K0/M-SEFZN	82405	25	23	±0.25%	128.5	57	71.5	103.5	50
KL 500-5K0/M-SEFZN	82240	50	-	±1%	188.5	82	106.5	138.5	75
KL 500-5K0/M-SEFZN	82388	50	48	±0.25%	188.5	82	106.5	138.5	75

Menge	Einh.	Artikel Nr.	Ind.	Bezeichnung 1	Bezeichnungen
1	A	30.08.93	gm	4	
2	A	14.06.96	og	5	Vorg.Zchng:
3	A	04.07.97	gm	6	Folge-Zchng:
Gezeichnet		09.02.93	gjm	Projektion	
Geprüft		4.7.97	gjm	Massstab	
Namegepr.				2:1	
Freigabe				Allg. od. SN	
				258440	
				mittel	
				T. Kl. 07.03	
				Bezeichn. 1 MB KL-SEFZN (Kabel)	
				Bezeichn. 2 KL 100-1000	
				CONTELEC AG	
				CH-2503-BIEL	
				MB3	
				12923	
				A 99	

Für diese Zeichnung behalten wir uns alle Rechte vor

# 提夫自控技术（上海）有限公司

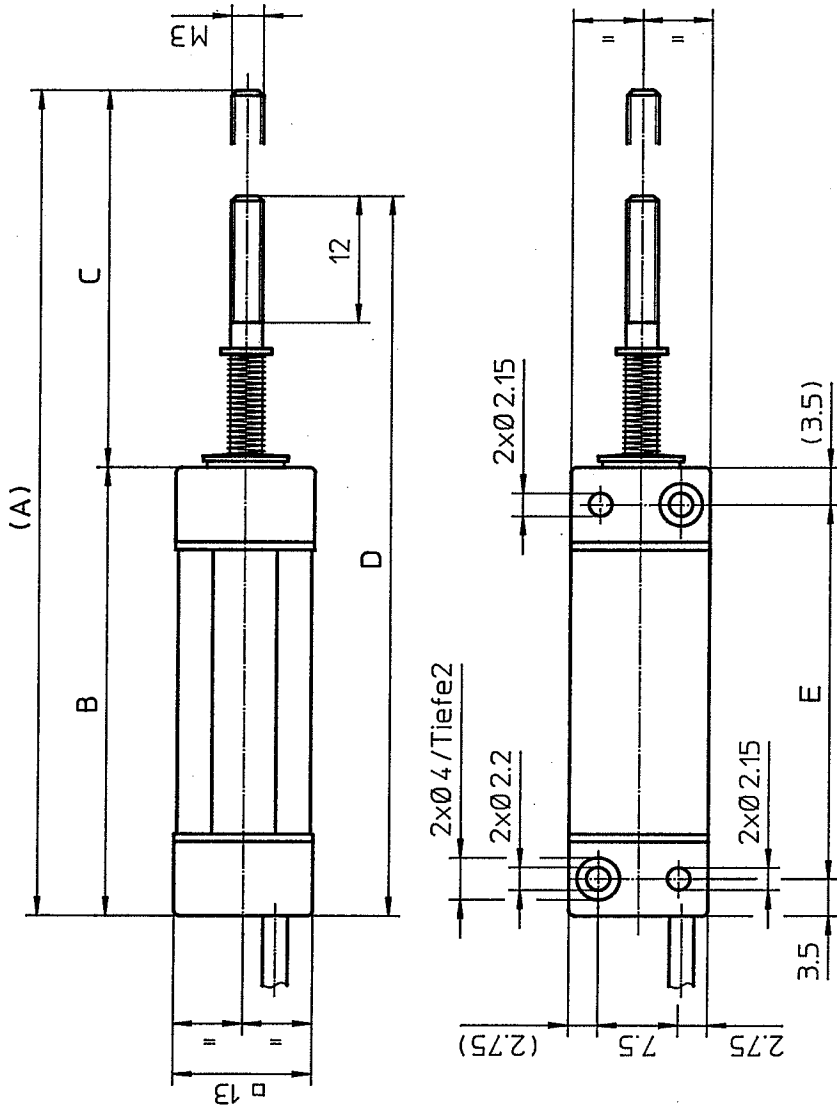

Typ	Art.-Nr.	Elektr. Hübänge gesamt	linearisiert	Linearität	A	B	C	D	E
KL 100-1K0/M-SEF	70436	10	-	±1%	77.5	42	35.5	67.5	35
KL 100-1K0/M-SEF	70824	10	9	±0.5%	77.5	42	35.5	67.5	35
KL 150-1K0/M-SEF	82825	15	-	±1%	95.5	47	48.5	80.5	40
KL 250-5K0/M-SEF	70439	25	-	±1%	117.5	57	60.5	92.5	50
KL 250-5K0/M-SEF	70827	25	23	±0.25%	117.5	57	60.5	92.5	50
KL 500-5K0/M-SEF	70442	50	-	±1%	177.5	82	95.5	127.5	75
KL 500-5K0/M-SEF	70830	50	48	±0.25%	177.5	82	95.5	127.5	75

Menge	19.07.93 br	Artikel Nr.	Ind.	Bezeichnung 1	Bemerkungen	
1	4 A 03.07.97 gm	4 A	03.07.97 gm	Massstab	2:1	Vorg. Zchnng: 11903A vom 03.07.97
2	27.08.93 gm	5 B	11.09.97/A317 gm	Projektion	2:1	Folge-Zchnng:
3	15.02.94 ng	6 B	13.02.98 gm	Alg. Nr.	SN 258440	T. Kl. 07.03
Gezeichnet	05.08.91	gm	mittel			
Geprüft	16.02.98	st	Bezeichnung 1 MB KL-SEF (Kabel)			
Normgepr.	Bezeichnung 2 KL100/250/500					
Fertigabe	CONTELEC AG CH-2503-BIEL					

Für diese Zeichnung behalten wir uns alle Rechte vor

**CONTELEC**

MB3

12903 B

99

# 提夫自控技术（上海）有限公司

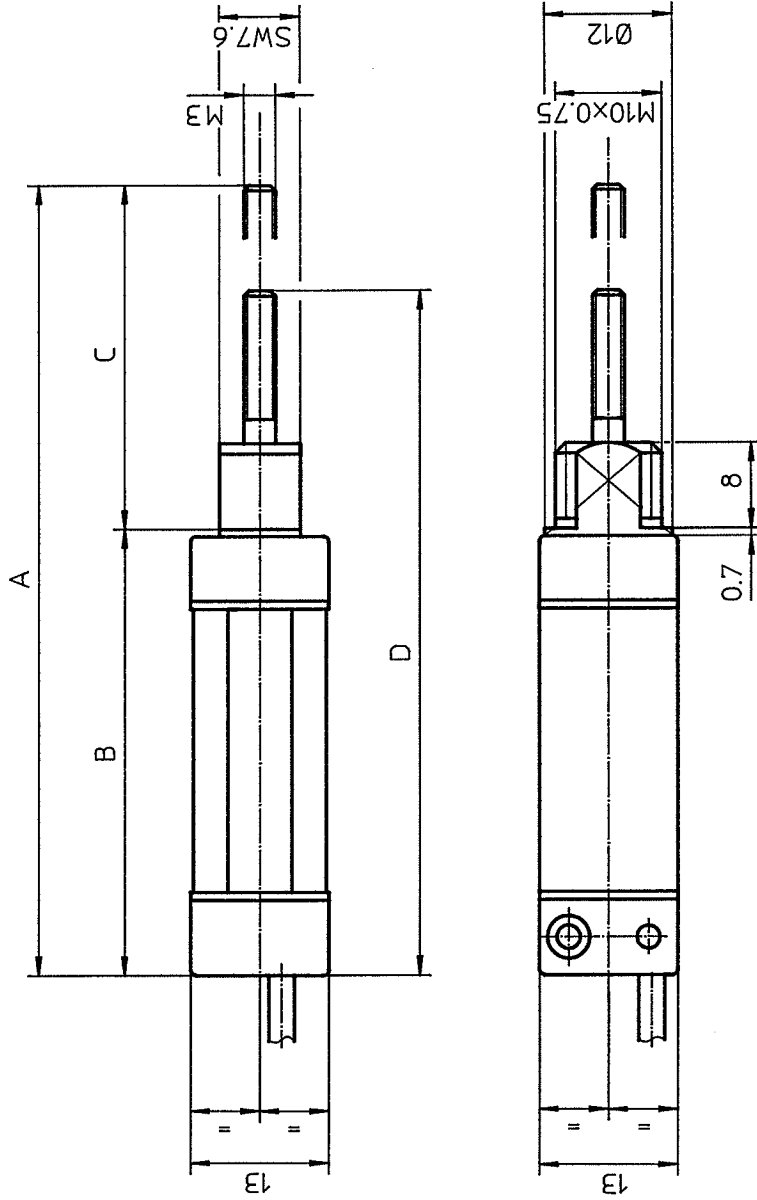

Typ	Art.-Nr.	Elektr. Hublänge gesamt	linearisiert	Linearität	A	B	C	D
KL 100-1K0/M-SE ZM	82649	10	-	±1%	75.2	41.7	33.5	65.2
KL 100-1K0/M-SE ZM		10	9	±0.5%	75.2	41.7	33.5	65.2
KL 250-5K0/M-SE ZM	82650	25	-	±1%	105.2	56.7	48.5	80.2
KL 250-5K0/M-SE ZM		25	23	±0.25%	105.2	56.7	48.5	80.2
KL 500-5K0/M-SE ZM	82651	50	-	±1%	155.2	81.7	73.5	105.2
KL 500-5K0/M-SE ZM	82652	50	48	±0.25%	155.2	81.7	73.5	105.2
KL 750-5K0/M-SE ZM	82653	75	-	±1%	205.2	106.7	98.5	130.2
KL 750-5K0/M-SE ZM		75	73	±0.25%	205.2	106.7	98.5	130.2
KL 1000-5K0/M-SE ZM	82654	100	-	±1%	255.2	131.7	123.5	155.2
KL 1000-5K0/M-SE ZM	82655	100	98	±0.25%	255.2	131.7	123.5	155.2

Menge	Einh.	Artikel Nr.	Ind.	Bezeichnung 1	Bemerkungen
1	A	04.12.96	gm	4.	Vorg.Zchnng:
2	A	04.07.97	gm	5.	Folge-Zchnng:
3.				6.	
Gezeichnet	18.11.96	OG		Alig. tel. SN 258440	
Geprüft	4.07.97	WZ		mittel	
Normgepr.					T. Kl. 07.03
Freigabe					
Bezeichnung 1 MB KL-SE ZM (Kabel)					
Bezeichnung 2 KL 100-1000					
CONTELEC AG					12950
CH-2503-BIEL					A
CONTELEC					99
					MB3

Für diese Zeichnung behalten wir uns alle Rechte vor

# 提夫自控技术（上海）有限公司

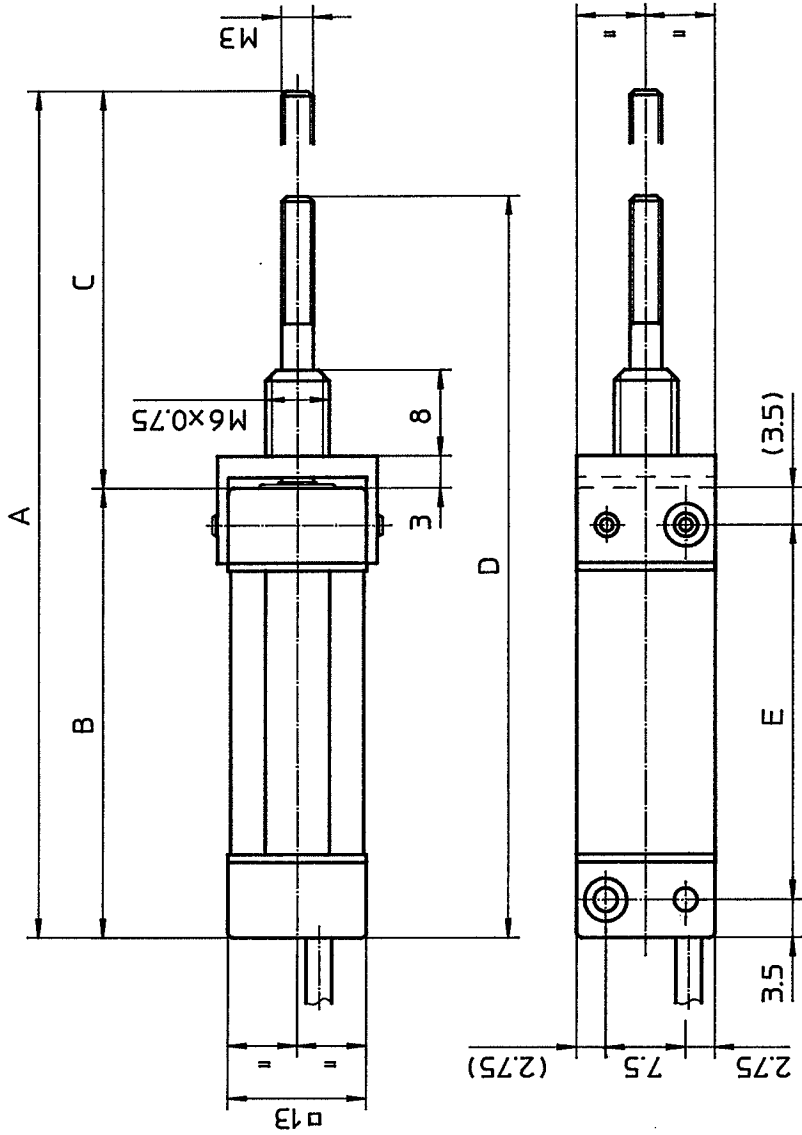

Typ	Art.-Nr.	Elektr. Hublänge gesamt	Hublänge linearisiert	Linearität	A	B	C	D	E
KL 100-1K0/M-SE ZN	82298	10	-	±1%	78.5	42	36.5	68.5	35
KL 100-1K0/M-SE ZN		10	9	±0.5%	78.5	42	36.5	68.5	35
KL 250-5K0/M-SE ZN	82237	25	-	±1%	108.5	57	51.5	83.5	50
KL 250-5K0/M-SE ZN		25	23	±0.25%	108.5	57	51.5	83.5	50
KL 500-5K0/M-SE ZN	82239	50	-	±1%	158.5	82	76.5	108.5	75
KL 500-5K0/M-SE ZN	82408	50	48	±0.25%	158.5	82	76.5	108.5	75
KL 750-5K0/M-SE ZN	82320	75	-	±1%	208.5	107	101.5	133.5	100
KL 750-5K0/M-SE ZN		75	73	±0.25%	208.5	107	101.5	133.5	100
KL 1000-5K0/M-SE ZN	82243	100	-	±1%	258.5	132	126.5	158.5	125
KL 1000-5K0/M-SE ZN	82409	100	98	±0.25%	258.5	132	126.5	158.5	125

Menge	Einh.	Artikel Nr.	Ind.	Bezeichnung 1	Bezeichnung 2	Bezeichnungen
5	1	A 27.08.93 gm	4	A 04.12.96 gm		Vorg.Zchnng:
5	2	A 14.06.96 og	5	A 04.07.97 gm		Folge-Zchnng:
5	3	A 12.11.96 og	6			T. Kl. 07.03
Gezeichnet	28.06.93	gm	☉			
Geprüft	4.07.97	W/				
Normgepr.						
Freigabe						
				Massstab 2:1		Projektion
				Allg. td. SN 258440		
				mittel		
				Bezeichn. 1 MB KL-SE ZN (Kabel)		
				Bezeichn. 2 KL 100-1000		
				CONTELEC AG		
				CH-2503-BIEL		
				MB3		
				12924 A 99		

Für diese Zeichnung behalten wir uns alle Rechte vor

# 提夫自控技术（上海）有限公司

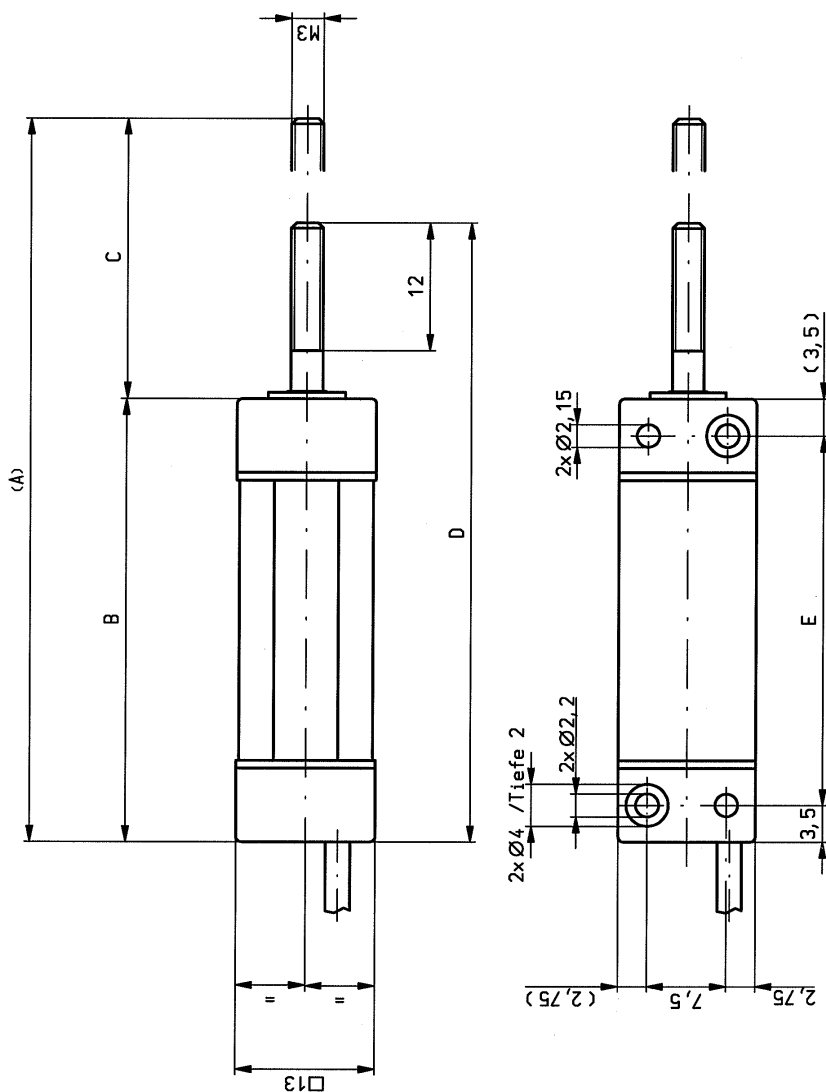

Typ	Art. Nr.	Elektr. Hub	Linearit	A	B	C	D	E
KL 100-1K0/M-SE	70438	10	±1%	68.5	42	26.5	58.5	35
KL 100-1K0/M-SE	70823	10	±0.5%	68.5	42	26.5	58.5	35
KL 250-5K0/M-SE	70441	25	±1%	98.5	57	41.5	73.5	50
KL 250-5K0/M-SE	70826	25	±0.25%	98.5	57	41.5	73.5	50
KL 500-5K0/M-SE	70444	50	±1%	148.5	82	66.5	98.5	75
KL 500-5K0/M-SE	70829	50	±0.25%	148.5	82	66.5	98.5	75
KL750-5K0/M-SE	82318	75	±1%	198.5	107	91.5	123.5	100
KL750-5K0/M-SE	.	75	±0.25%	198.5	107	91.5	123.5	100
KL1000-5K0/M-SE	82241	100	±1%	248.5	132	116.5	148.5	125
KL1000-5K0/M-SE	.	100	±0.25%	248.5	132	116.5	148.5	125

Pos	Menge	EH	Abmessung	Werkstoff	Name	Art. Nummer	
2							
6							
5							
4							
3							
2							
1							
Gewicht		Allg. Tol.		SN		I. KL	
MB3		12915		MB KL-SE		-	
Bez. 1		Bez. 2		KL100/250/500/750/1000			
F:12915-A		CONTELEC AG		CH-2503 BIEL		Blatt 1	
A		99					